

# THE CITY OF DAWSON

Box 308 Dawson City, YT Y0B 1G0  
PH: 867-993-7400 FAX: 867-993-7434  
[www.cityofdawson.ca](http://www.cityofdawson.ca)



## NOTICE OF SPECIAL COUNCIL MEETING #C18-11

This is to inform you a special meeting of City Council will be held as follows:

**DATE OF MEETING:** WEDNESDAY, MARCH 21, 2018  
**PLACE OF MEETING:** COUNCIL CHAMBERS, CITY OFFICE  
**TIME OF MEETING:** 12:00 PM

### PURPOSE OF MEETING:

- a) Request for Decision RE: Contract Award for Swimming Pool Upgrades

DATE MEETING REQUESTED: March 19, 2018  
MEETING REQUESTED BY: WAYNE POTOROKA, MAYOR

Original signed by: \_\_\_\_\_ March 20, 2018  
Cory Bellmore, CAO Date

# THE CITY OF DAWSON

## Request for Decision



---

TO: Mayor and Council  
FROM: Trina Buhler, Project Manager City of Dawson  
DATE: March 19, 2018  
SUBJECT: Swimming Pool Wall Repair and Support Structure Repair Sole Source Contract Award

---

### RECOMMENDATION

THAT Council award a sole source contract with Priority SS for the swimming pool support structure repair only for the estimated amount of \$97,800.00

### PURPOSE

To ensure the continuity of indoor aquatic sports in Dawson City.

To provide Council with an update on the results of the sole source process.

### BACKGROUND

The City of Dawson received an estimate from the only Canadian supplier of Myrtha brand pool materials in Canada, NC Aquatics. Based on this estimate Administration secured funding and began the following competitive processes:

- Pool Wall Repair RFP
- Support Structure Repair and Replacement RFQ

The tenders ran from January 29 – February 19 and were posted locally and on Biddingo.ca. The tenders were covered by CBC news and one contractor requested and was provided a site visit.

We were notified by NC Aquatics (the only Canadian supplier of Myrtha brand pool materials) that they would not be able to participate in the competitive process as it would be a conflict of interest as they would be in competition with the authorized Myrtha brand installers to whom they provide materials to.

The tender closed, and the City did not receive any bids or proposals.

The project manager has spoken with two Myrtha authorized installers and both noted that it is a particularly busy time of year.

Based on this, Administration requested permission to sole source the work to NC Aquatics.

Council authorized the negotiation of a sole source contract for the work:

*Moved by Mayor Potoroka, seconded by Councillor MacArthur that Council waive the appropriate procurement methodology as allowed in items 4 and 5 of Policy #14-02 and authorize the negotiation of a sole source contract(s) for the swimming pool wall repair and the swimming pool support structure repair. Motion Carried 5-0*

The City of Dawson researched options to use local expertise, however to ensure the warranty on the pool wall repair, the support structure repair also had to be completed by a Myrtha authorized installer. There are not any Myrtha authorized installers in the Yukon.

The City of Dawson contacted NC Aquatics for a formal quote to complete the work identified in **Request for Decision Swimming Pool OHS Requirements, Budget Amendment and Gas Tax Application**. NC Aquatics deferred the request for quote to Priority SS, a Myrtha authorized installer out of Milton, ON.

CURRENT STATUS
----------------

The City received a formal quote of \$97,800.00 from Priority SS to complete the structural support work only as identified in **Request for Decision Swimming Pool OHS Requirements, Budget Amendment and Gas Tax Application**.

CONSIDERATIONS / DISCUSSION
-----------------------------

The scope identified in **Request for Decision Swimming Pool OHS Requirements, Budget Amendment and Gas Tax Application** is required by OHS prior to opening in 2018.

To reduce risk associated with timeline, the City of Dawson is proposing to complete the project in two parts.

Part I            Complete structural support work in advance of the pool opening and patch the pool wall for the 2018 pool season.

Part II           Complete the permanent pool wall repair immediately after the pool closes in the fall.

This strategy is attractive to the Contractor as it allows them an opportunity to visit the site, complete the structural work and get a better understanding of the pool wall repair work to be completed in the fall which is costlier and time consuming.

A tentative schedule would be as follows:

Mar 19	Council Review – award sole source quote
Mar 23	Contract Signing and Pre-Construction Meeting
Mar 26 – Apr 27	Structural Support Material Fabrication and Shipping (4 weeks)
Apr 30 – May 25	Structural Support Construction (4 weeks)
Aug 6 – Aug 31	Pool Wall Repair Material Fabrication and Shipping (4 weeks)
Sep 10 – Oct 19	Pool Wall Repair Construction (6 weeks)

IMPLICATIONS
--------------

General:

The listed actions are required by OHS prior to opening in 2018.

Staffing:

Awarding this project will mean an investment in time by the Project Manager for planning and administering the contract.

Financial:

Council has approved the use of Gas Tax funding for this project. The application is currently in process.

Policy / Legislated Requirements:

The action required for compliance to the OHS order is to provide a work plan to implement the required remediation as per the "Structural Assessment Report: City of Dawson Swimming Pool" dated August 31, 2017 by Mr. Noel Carpina M. Sc Eng P. Eng.

Legal:

The City of Dawson has shown justification to sole source this work.

Follow up Action:

If awarded, Administration will formally notify Priority SS to obtain the necessary documents and schedule the work.

Communication:

Not applicable.

RELEVANT CONSULTATION

Not applicable.

ALIGNMENT TO OFFICIAL COMMUNITY PLAN & MUNICIPAL PRIORITIES

Bylaw No. 12-23:

Official Community Plan:

*Maintain and develop quality recreational infrastructure and facilities.*

OPTIONS

1. THAT Council award a sole source contract with Priority SS for the swimming pool support structure repair for the estimated amount of \$97,800.00
- OR
2. THAT Council not award a sole source contract with Priority SS.

APPENDICES / SCHEDULES

***Request for Decision Swimming Pool OHS Requirements, Budget Amendment and Gas Tax Application***

***Dawson City Stage 1***

APPROVAL & CAO COMMENTS

CAO: Reviewed and approved this request. Cbellmore

Date: March 19/18

# THE CITY OF DAWSON

## Request for Decision



---

TO: Mayor and Council  
FROM: Trina Buhler, Project Manager City of Dawson  
DATE: January 12, 2017  
SUBJECT: Swimming Pool OHS Requirements, Budget Amendment, and Gas Tax Application

---

### RECOMMENDATION

THAT Council approve an amendment to the 2018 capital budget in the amount of \$306,250.00; and

THAT Council provide feedback on the OHS items to be included in the scope of work of the Swimming Pool RFP; and

THAT Council direct Administration to apply for Gas Tax Funding for the OHS items at the Swimming Pool.

### PURPOSE

To ensure the continuity of indoor aquatic sports in Dawson City.

To provide Council with an update on work required on the pool including a status of the pool, to establish funds for pool upgrades, to provide feedback on the work required, and to direct administration to seek funds from Gas Tax to cover the cost of the pool upgrades.

### BACKGROUND

The pool building was constructed in 2000 and a Myrtha brand pool installed.

In the spring of 2017, the City of Dawson contacted Master Pools to conduct an inspection of the Dawson City Swimming Pool after concerns re loss of water and structural supports were noted by the facility operators.

On June 24, 2017 Master Pools, a Myrtha brand pool authorized installer and the company hired to originally install the pool, provided a report outlining the findings from their June 21, 2017 on-site inspection.

On August 31, 2017 Yukon Engineering Services, contracted by OHS, provided a structural assessment of the swimming pool structure based on the findings from their August 17, 2017 on-site inspection.

Based on these reports the following actions listed are required by OHS and will be the basis for the scope of work to ensure the continuity of indoor aquatic sports in 2018:

1. Conduct onsite water leak detection test of the swimming pool area by an expert pool technician and repair or reseal permanently the suspected or identified leak points with appropriate wet liner patch kit or approve equal recommended by pool experts.
2. Replace corroded base plates with new galvanized 100x100x4.8mm base plates as shown in structural details below.
3. Remove corroded materials with wire brush and apply steel paint to the rusted bolts with an oxygen barrier primer such as Par 15 and finish to match existing. Also, tighten the loose nuts and washer using wrench and apply two part of epoxy resin onto the threads to restrict the nuts from loosening.
4. Replace all deteriorated or rotten wooden sill plates with new 2x6 pwf lumber under the supervision of a Professional Structural Engineer. Anchoring or log screws to be used must be galvanized materials to minimize corrosion due to constant moisture and exposure to water ponding. Structural support or formworks of the main floor must also be provided before or during the replacement of the affected bottom sill plates under the supervision of a Professional Structural Engineer.
5. Replace all existing horizontal steel brace with new angle L 51x38x4.8mm (galvanized) and corroded base plates with new 100x100x4.8mm (galvanized) base plates as shown in structural details below under the supervision of a Professional Structural Engineer.
6. Remove corroded materials with wire brush and apply steel paint to the rusted bolts with an oxygen barrier primer such as Par 15 and finish to match existing. Also, tighten the loose nuts and washer using wrench and apply two part of epoxy resin onto the threads to restrict the nuts from loosening.

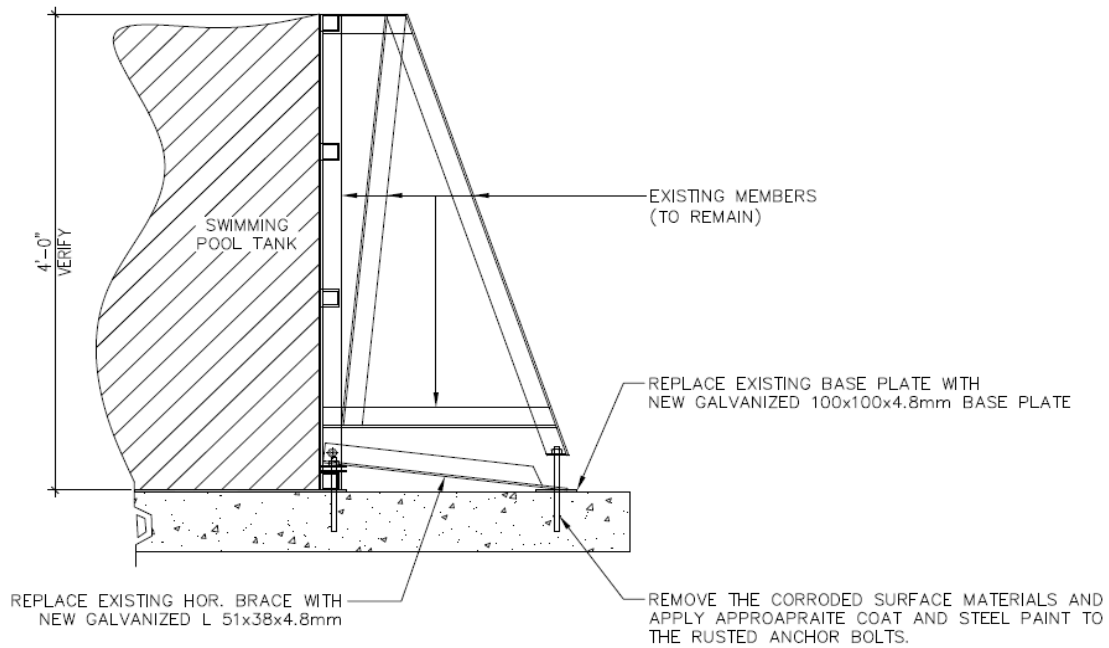

#### CURRENT STATUS

The City of Dawson has received an estimate from an authorized Myrtha brand pool installer and is awaiting an estimate from a second authorized installer. Based on this, Administration is requesting Council amend the 2018 capital budget to include \$306,250.00 prior to the City tendering this work via Request for Proposals (RFP).

Feedback from Council regarding the actions listed is requested at this time and will be incorporated in the RFP.

Direction from Council regarding whether to apply for Gas Tax funding for the actions listed is requested.

#### CONSIDERATIONS / DISCUSSION

The listed actions are required by OHS prior to opening in 2018. Failure to complete this work would result in pool closure until this work is completed.

A tentative schedule would be as follows:

Jan 22	Committee of the Whole Review – secure funds
Feb 12	Council Review – secure funds
Feb 13	Issue Request for Quotes (3 weeks)
Mar 6	Tender Deadline
Mar 12	Committee of the Whole Review – award tender

Mar 19	Council Review – award tender
Mar 20	Award Tender
Mar 21	Material Fabrication and Shipping (4 weeks)
Apr 18	Construction Starts (3 weeks)
May 9	Construction Ends

The above schedule does not leave much room for error or delay. If Administration could tender the work prior to the securing of funds through a caveat that "award is dependent on appropriation of funds" the tendering process could move ahead in advance of the Feb 19 Council Review.

Awarding of the successful proposal will come back to Committee of the Whole on March 12 and Council on March 19.

#### IMPLICATIONS

##### General:

The listed actions are required by OHS prior to opening in 2018.

##### Staffing:

Awarding this project will mean an investment in time by the Project Manager for planning and administering the contract.

##### Financial:

Gas tax funding will be requested.

##### Policy / Legislated Requirements:

The action required for compliance to the OHS order is to provide a work plan to implement the required remediation as per the "Structural Assessment Report: City of Dawson Swimming Pool" dated August 31, 2017 by Mr. Noel Carpina M. Sc Eng P. Eng.

##### Legal:

A legal opinion is not required.

##### Follow up Action:

Not applicable.

##### Communication:

Not applicable.

#### RELEVANT CONSULTATION

Not applicable.

ALIGNMENT TO OFFICIAL COMMUNITY PLAN & MUNICIPAL PRIORITIES

Bylaw No. 12-23:

Official Community Plan:

*Maintain and develop quality recreational infrastructure and facilities.*

OPTIONS

1. THAT Council approve an amendment to the 2018 capital budget in the amount of \$306,250.00.
- OR
2. THAT Council not approve an amendment to the 2018 capital budget in the amount of \$306,250.00.

AND

1. THAT Council provide feedback on the OHS items to be included in the scope of work of the Swimming Pool RFP;

AND

1. THAT Council direct Administration to apply for Gas Tax Funding for the OHS items at the Swimming Pool.
- OR
2. THAT Council direct Administration to not apply for Gas Tax Funding for the OHS items at the Swimming Pool.

APPENDICES / SCHEDULES

Swimming Pool Structural Assessment Report – August 31, 2017  
NCA Budget Dawson Pool Walls 20171211 – December 11, 2017  
NCA Budget Dawson Struts 20171211 – December 11, 2017

APPROVAL & CAO COMMENTS

CAO:

Date:

PRIORITY SS  
405 INDUSTRIAL DRIVE UNIT 9  
MILTON, ON L9T 5B1  
PHONE 905-691-1875  
EMAIL [lee.hulan@priorityss.ca](mailto:lee.hulan@priorityss.ca)



March 16, 2018

**TO:** Trina Buhler

**RE:** Dawson City Pool

**SCOPE:** Myrtha Pool Structural Repair

- Cut and remove all affected existing struts
- Cut and remove affected threaded bolts and install new offset plates
- Inspect buttresses, clean and passivate as required
- Supply and install new struts at each buttress location, offset from existing buttresses

Price: **\$97,800** Materials, labour, freight and travel expenses

Terms: 10% deposit with order

50% to schedule shipment

Remainder due last day on site

Quote valid for 60 days

Taxes to be applied

Based on our schedules, we are able to come to Dawson City in mid-April and complete the work in approximately two weeks.

After reviewing your request regarding the sill plates, it would not be cost effective for you to have us quote that work with the limited knowledge we have of the situation. We can review this once we are on site, and advise your team on the best course of action. We will work with you to the best of our ability, on a time and material basis in order to ensure completion. We will come back in the fall to perform the pool renovation, when schedule permits.

This quote excludes the following:

- Removal and replacement of in pool lighting fixtures
- Access ladders, grab rails, floor and wall inlets, deck anchors, lamps, main drains and/or grating, float line, lane dividers, stanchions, depth markings, gutter coping, gutter grating
- Filling of pool with water (water, heating, chemical treatment and filling by client)
- Excludes all concrete works
- Excludes all electrical works and materials
- Excludes all under deck mechanical works

Regards,

Lee Hulan